

# PRECAST IN INFRASTRUCTURE BRIDGES, FLYOVERS, METRO RAIL.....

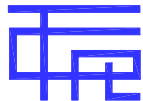

TANDON CONSULTANTS PVT. LTD.



STRUCTURAL ENGG. SPECIALISTS

**VINAY GUPTA**  
**CHIEF EXECUTIVE OFFICER**  
**TANDON CONSULTANTS PVT LTD**  
**NEW DELHI**

**METRO PROJECTS**

**LRT, MALAYSIA**



**URBAN BRIDGE WITH COMPLEX ALIGNMENT TO  
AVOID OBSTACLES**

TANDON CONSULTANTS PVT. LTD.



STRUCTURAL ENGG. SPECIALISTS



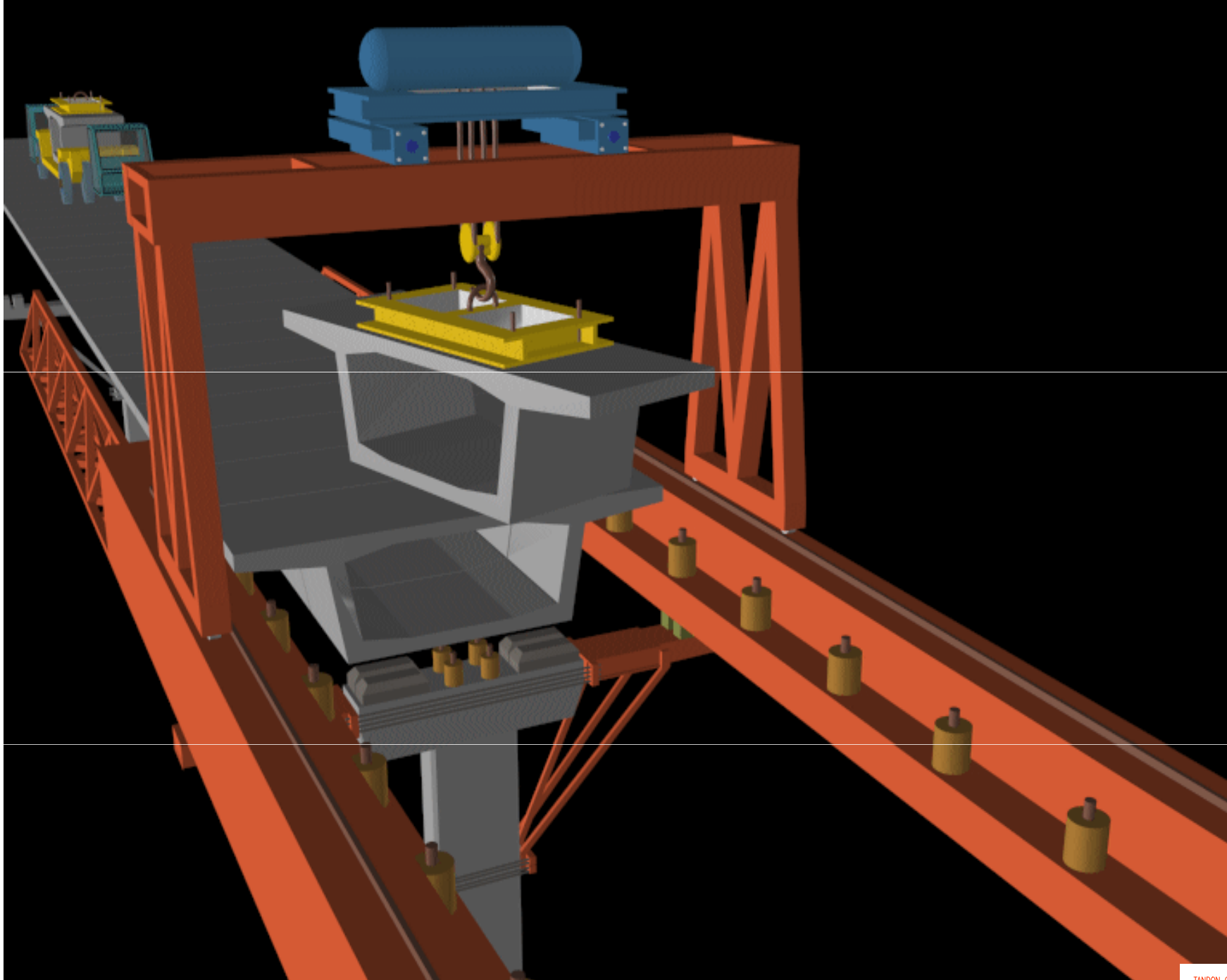

# LRT FOR KUALA LUMPUR ERECTION OF SEGMENTS

TANDON CONSULTANTS PVT. LTD.



STRUCTURAL ENGG. SPECIALISTS





**INSIDE VIEW OF BOX SHOWING EXTERNAL CABLES**  
**LRT, KUALA LUMPUR**



# DELHI METRO : SEGMENTAL CONSTRUCTION

(STANDARD SPANS 21.6m to  
29.1m)







## PRECAST SEGMENTAL CONSTRUCTION USING OVERHEAD LAUNCHING GIRDER

TANDON CONSULTANTS PVT. LTD.



STRUCTURAL ENGG. SPECIALISTS





**DMRC: PRECAST SEGMENTAL CONSTRUCTION  
USING UNDERSLUNG ASSEMBLY GIRDER**

TANDON CONSULTANTS PVT. LTD.



STRUCTURAL ENGG. SPECIALISTS

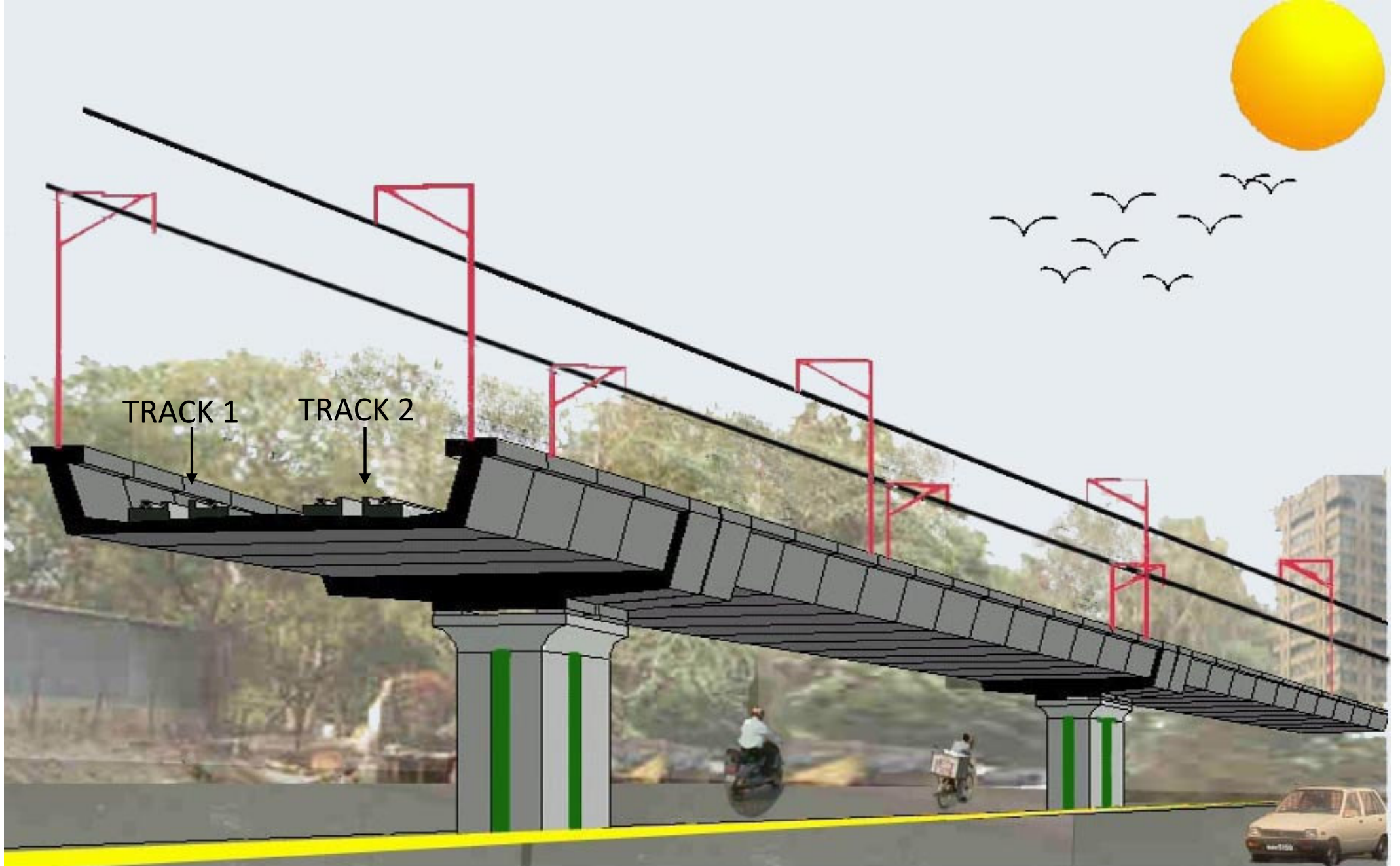

**DMRC LINE 3: VIADUCT USING U-GIRDER  
ARTIST'S IMPRESSION**





# 75T PIER SEGMENT BEING RAISED TWIN TRACK VIADUCT

TANDON CONSULTANTS PVT. LTD.



STRUCTURAL ENGG. SPECIALISTS



Twin-spans from 36m to 44m

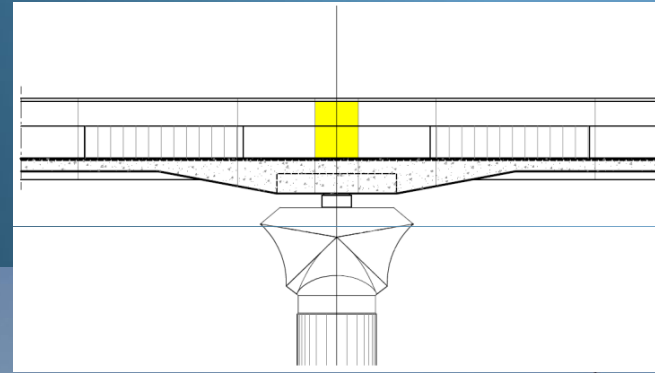

# PIERCAP





# PIERCAP







## DMRC NOIDA-GREATER NOIDA METRO





**BMRCL**

**METRO STATIONS**







# PRECAST STATION UNDER CONSTRUCTION





## UNDERSIDE VIEW FROM ROAD BELOW

TANDON CONSULTANTS PVT. LTD.



STRUCTURAL ENGG. SPECIALISTS





## PRECAST PRETENSIONED GIRDERS FOR CONCOURSE, PLATFORM AND TRACK SUPPORTS

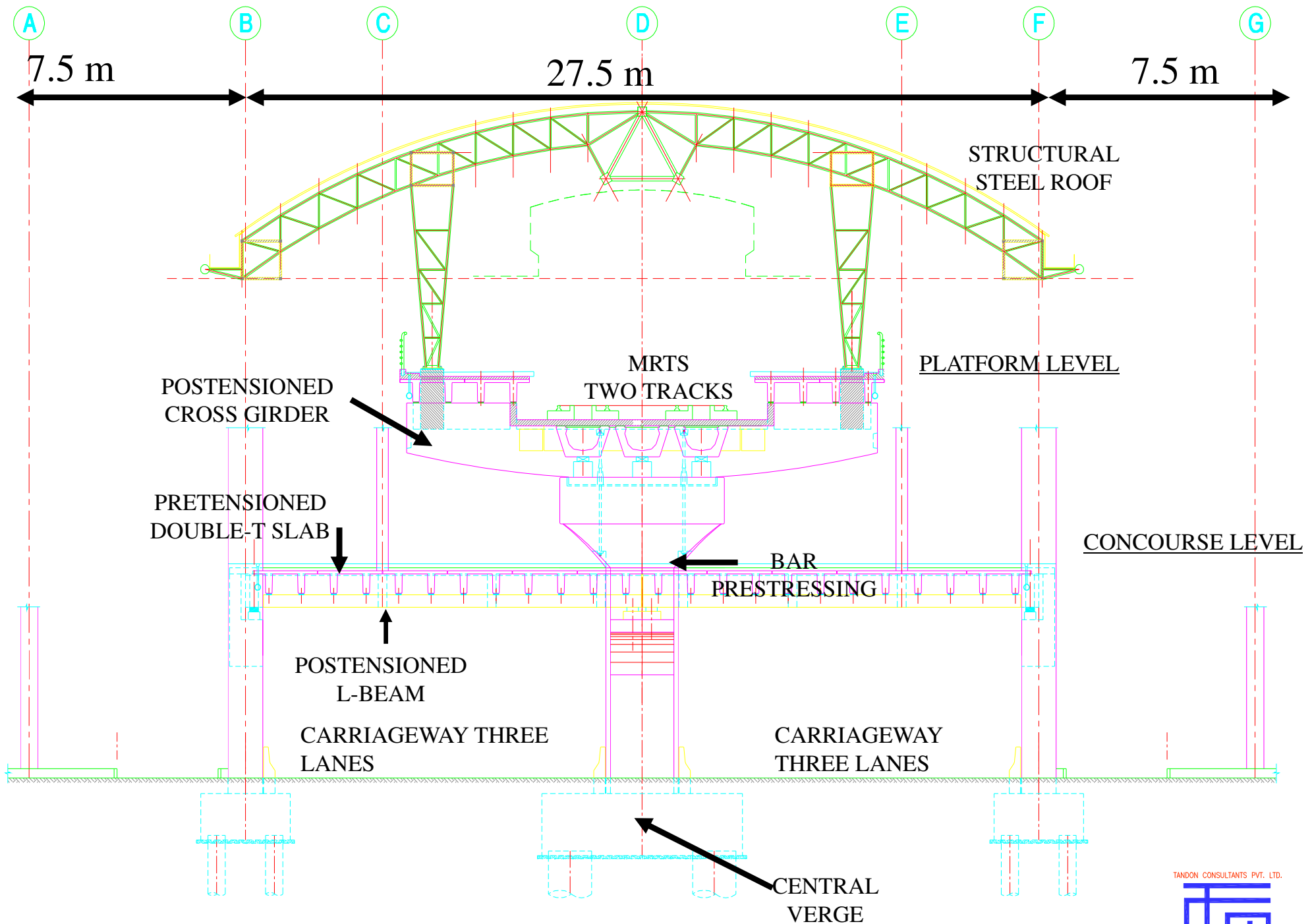

# DELHI METRO: STATIONS EMPLOYING PRECAST ELEMENTS





# CROSS GIRDER AND TRACK GIRDER IN POSITION





TRACK GIRDERS

DOUBLE 'T'  
PLATFORM

L-BEAM

BRACKET

# L-BEAMS, PLATFORM ERECTED





# STEEL ROOF ERECTION

TANDON CONSULTANTS PVT. LTD.



STRUCTURAL ENGG. SPECIALISTS



# **SAMTEL COLOR LTD FACTORY (GHAZIABAD)**



**ELEVATED EXPRESSWAYS**



**A TYPICAL URBAN ENVIRONMENT**





**THREE LEVEL INTERCHANGE (LOS ANGELES)**





# BANGALORE – HOSUR ELEVATED EXPRESSWAY





**FORWARD END**



# **BEGINNING OF LAUNCHING**





**CORDLESS REMOTE FOR ALL  
OPERATIONS OF LG ETC.**





# SEGMENTS SUSPENDED FROM LAUNCHING TRUSS





**LAUNCHING  
GIRDER  
(110M LONG)**

**UNDER SLUNG LAUNCHING TRUSS**





**HANDLING OF SEGMENTS ON UNDER SLUNG  
LAUNCHING TRUSS**



**SUPPORTING TROLLEY FOR THE SEGMENT TO  
MOVE OVER**



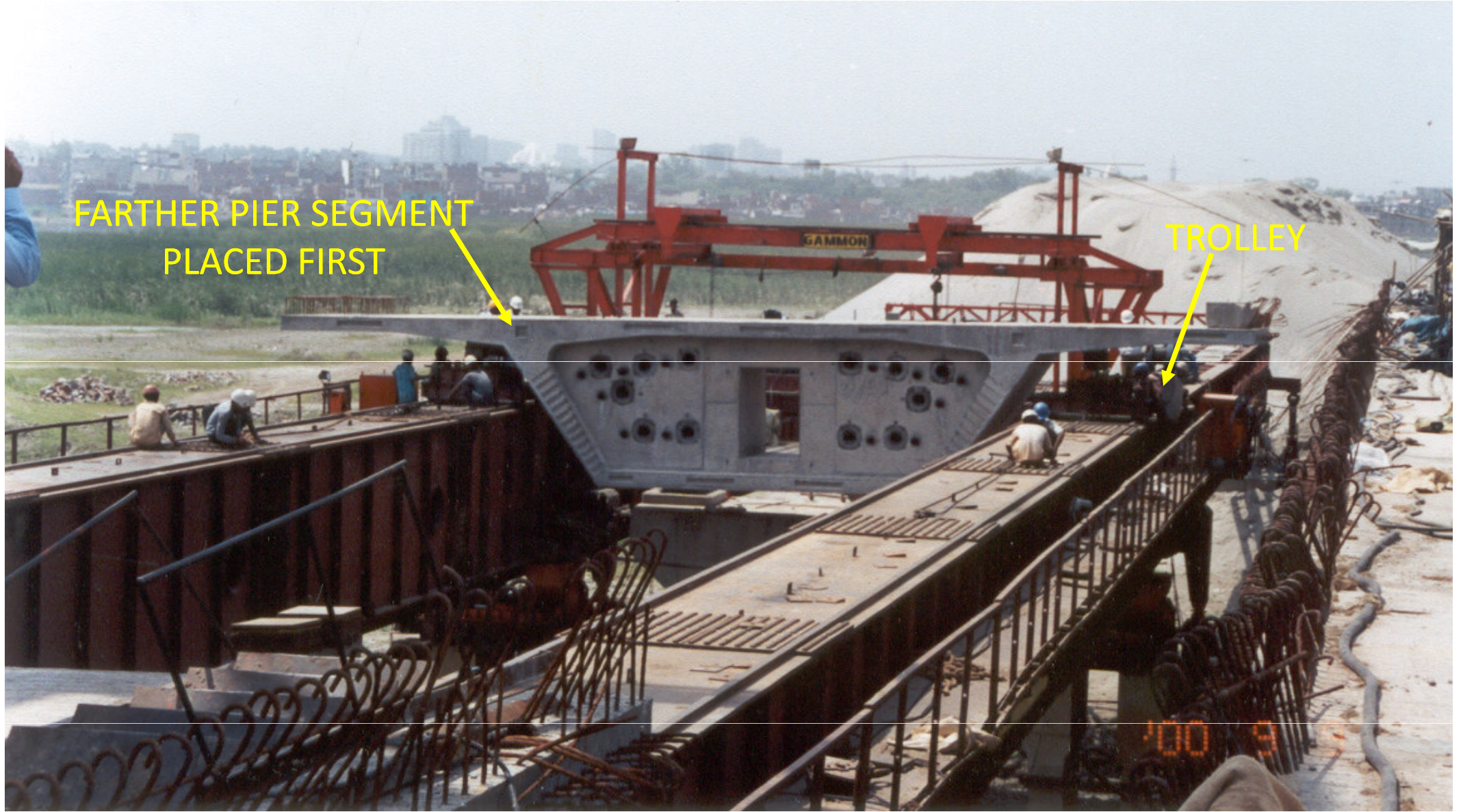

**ASSEMBLING**



J J HOSPITAL FLYOVER, MUMBAI

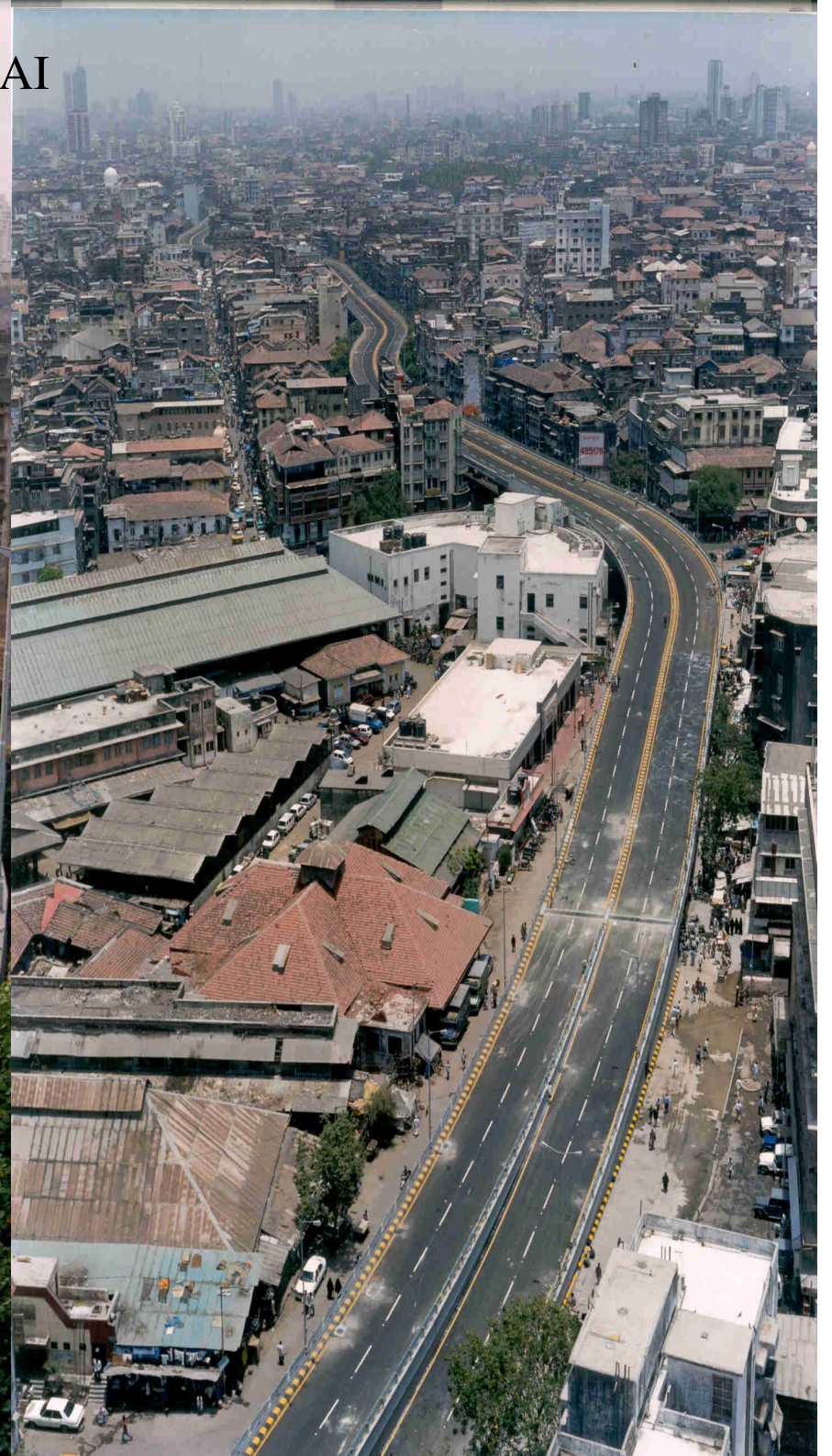



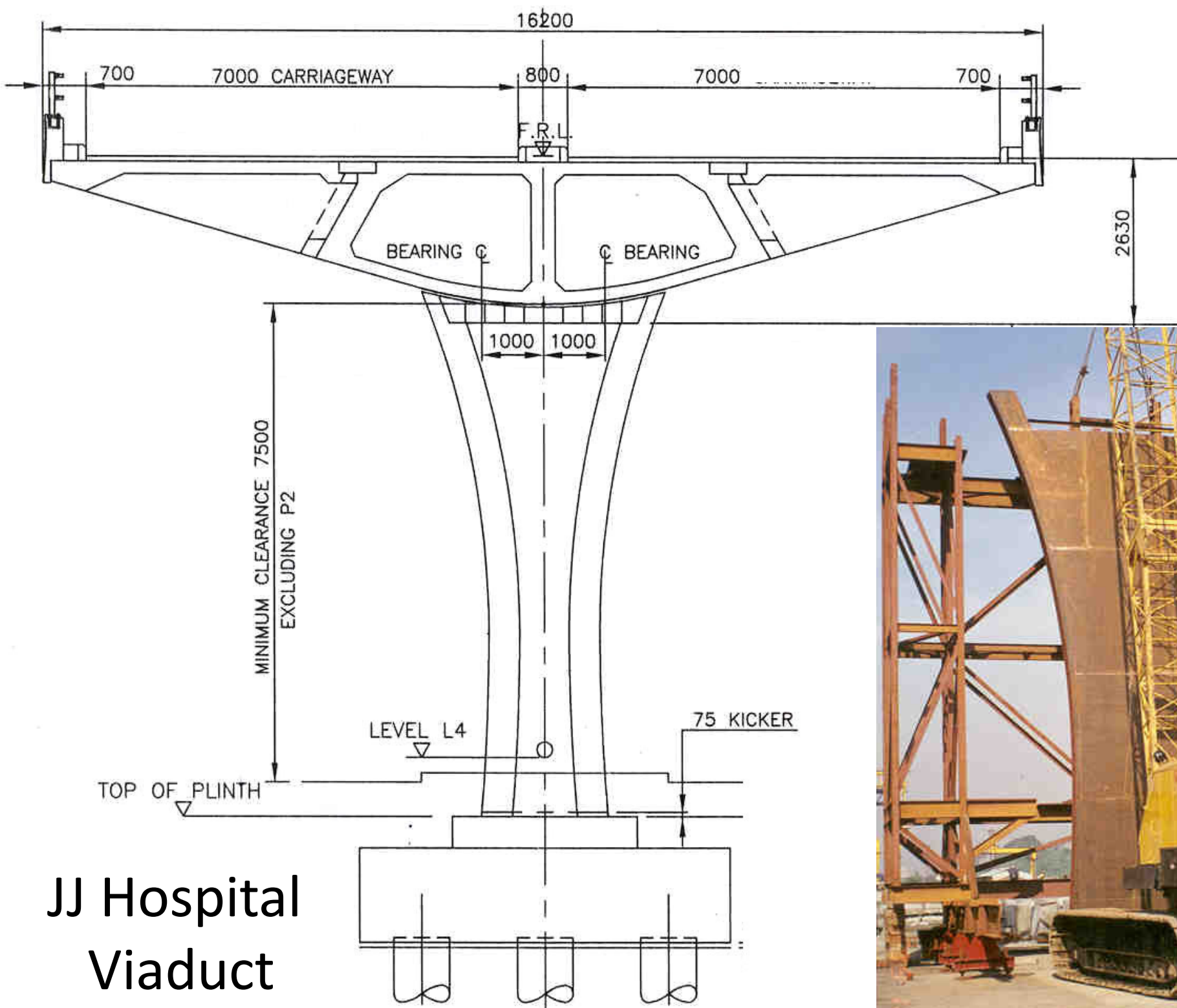

**JJ Hospital  
 Viaduct**





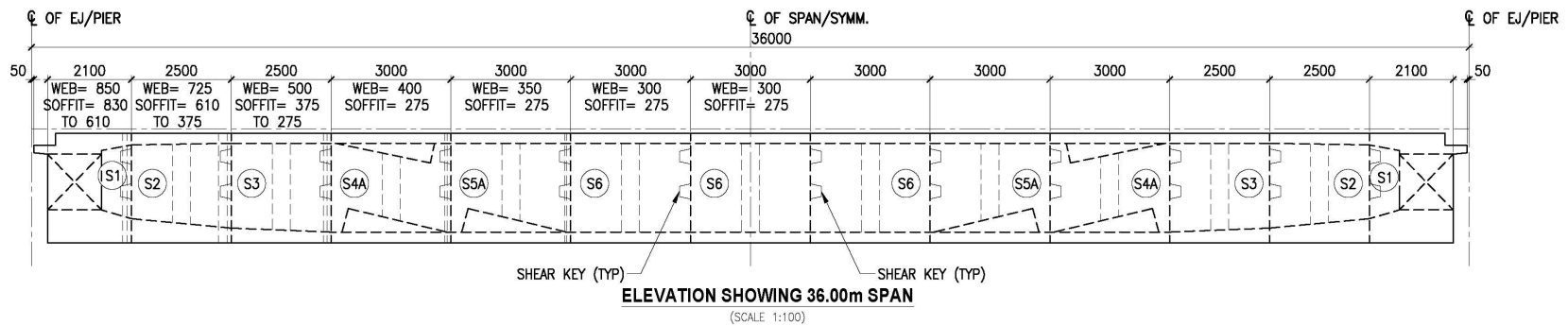
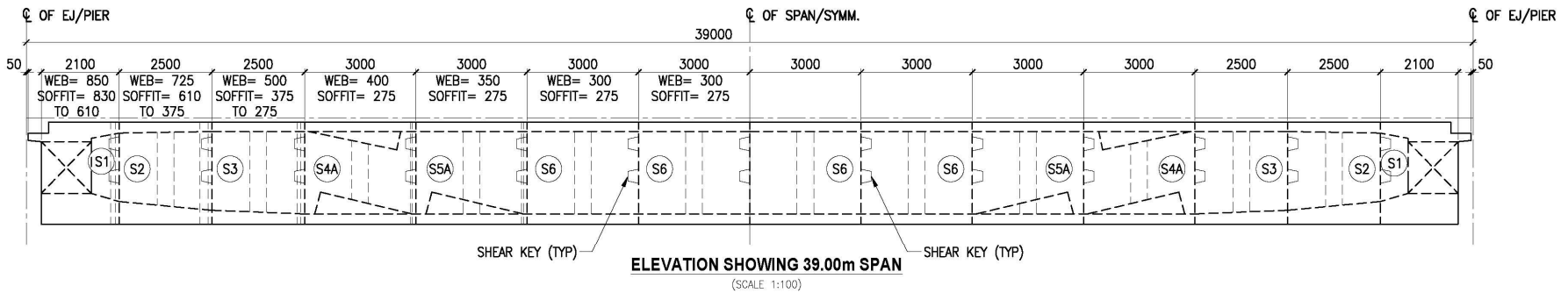
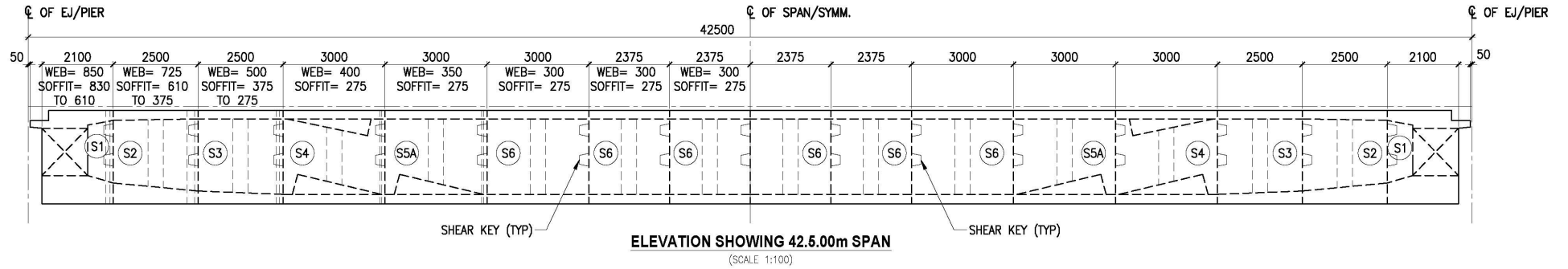
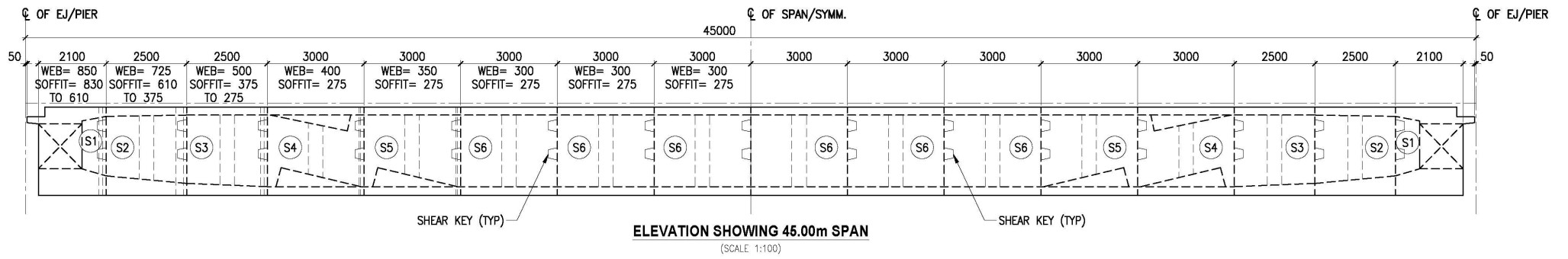





## **PRECAST SEGMENTAL BALANCED CANTILEVER CONSTRUCTION USING SEGMENT LIFTER**





# BARAPULLA ELEVATED EXPRESSWAY

24 9:56









# **BADARPUR ELEVATED EXPRESSWAY MODEL VIEW**





# **BADARPUR ELEVATED EXPRESSWAY COMPLETED VIEW**

TANDON CONSULTANTS PVT. LTD.



STRUCTURAL ENGG. SPECIALISTS





## PRECASTING BY MATCHCASTING

TANDON CONSULTANTS PVT. LTD.



STRUCTURAL ENGG. SPECIALISTS





# OUTER SHUTTER





# INTERNAL SHUTTER ON RAIL & COUNTER WEIGHT

TANDON CONSULTANTS PVT. LTD.



STRUCTURAL ENGG. SPECIALISTS





# DELHI – GURGAON EXPRESSWAY

TANDON CONSULTANTS PVT. LTD.



STRUCTURAL ENGG. SPECIALISTS





**GANTRY**

**CASTING BEDS**

**PRESTRESSING CHAMBER**

**PRECAST PRETENSIONED BEAMS**  
**OVERALL VIEW OF CASTING YARD**



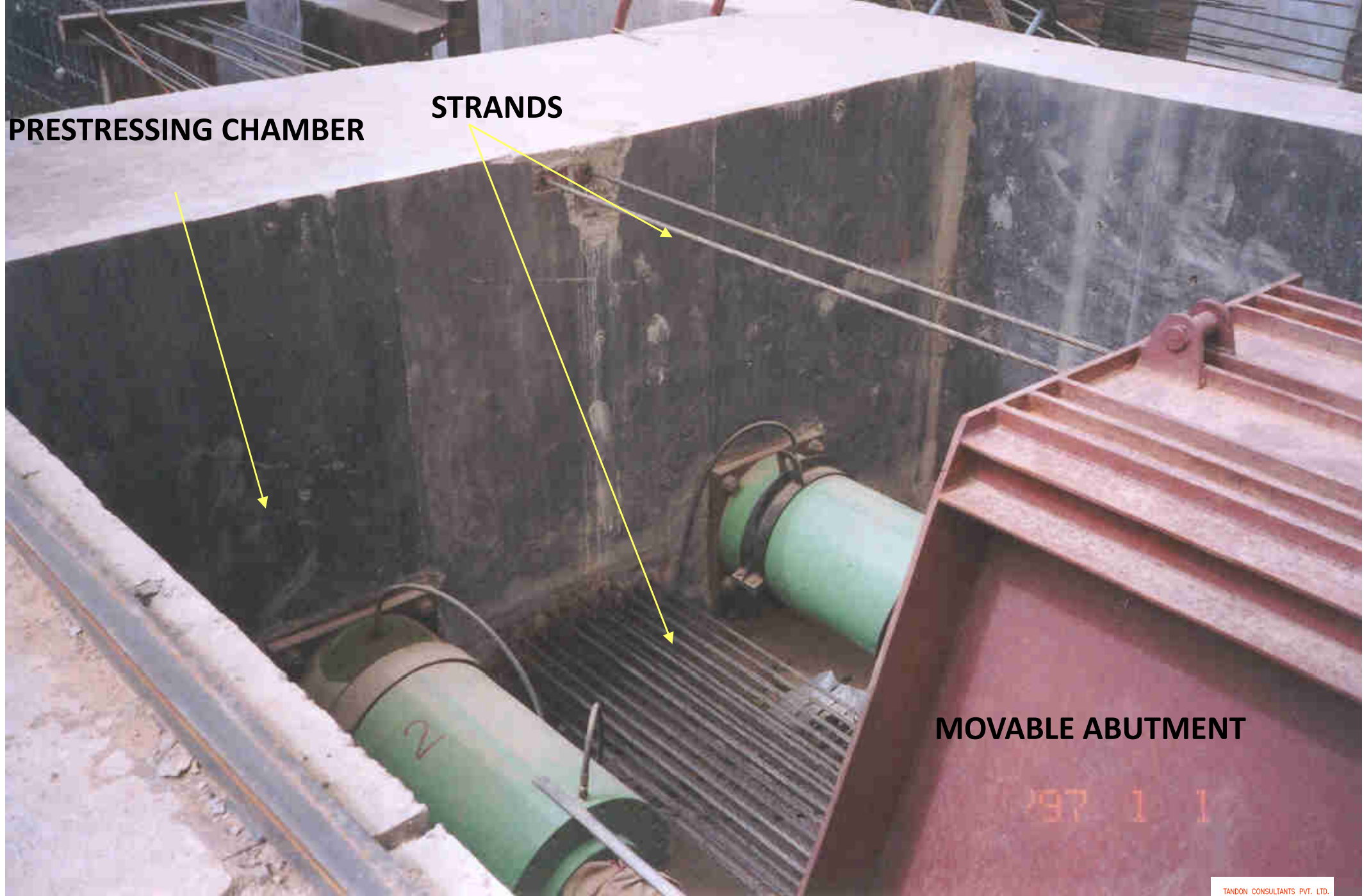

**PRESTRESSING CHAMBER**

**STRANDS**

**MOVABLE ABUTMENT**

# **PRECAST PRETENSIONED BEAMS ARRANGEMENT FOR PRESTRESSING**

TANDON CONSULTANTS PVT. LTD.



STRUCTURAL ENGG. SPECIALISTS





'04 9 29

TANDON CONSULTANTS PVT. LTD.



STRUCTURAL ENGG. SPECIALISTS





TANDON CONSULTANTS PVT. LTD.

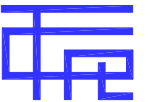

STRUCTURAL ENGG. SPECIALISTS







**OTHER STRUCTURES**







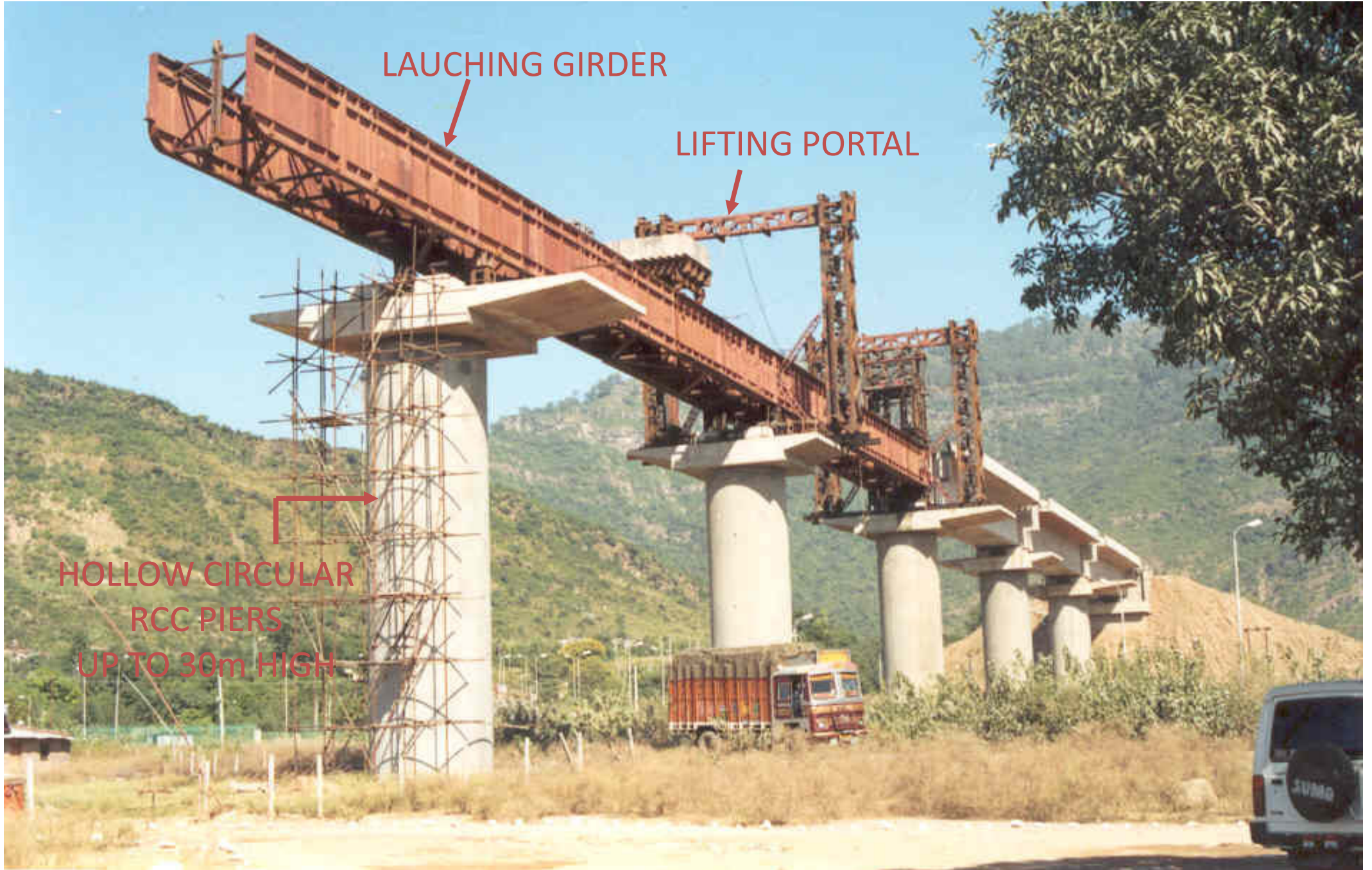

LAUNCHING GIRDER

LIFTING PORTAL

HOLLOW CIRCULAR  
RCC PIERS  
UP TO 30m HIGH

# JAMMU UDHAMPUR RAIL LINK - VIADUCT E18

TANDON CONSULTANTS PVT. LTD.



STRUCTURAL ENGG. SPECIALISTS





**JURL: VIADUCT E18**  
**LIFTING OF PSC GIRDER IN ORDER TO MOVE**  
**LAUNCHING GIRDER FORWARD**





**57 KM LONG BBB  
EXPRESSWAY,  
SOUTH BANGKOK,  
1999**

36 RAMPS, 2 ELEVATED TOLL  
PLAZAS OF 80m WIDTH EACH  
CONSISTING OF 6 PARALLEL BOX  
GIRDERS

'H' SHAPED PIERS SUPPORT  
TWO WEBS OF VIADUCT AND  
ASSEMBLY GANTRY BELOW





# PLACEMENT OF PRECAST SEGMENTS



**Thank You**

**VINAY GUPTA  
CHIEF EXECUTIVE OFFICER  
TANDON CONSULTANTS PVT LTD  
NEW DELHI**

